

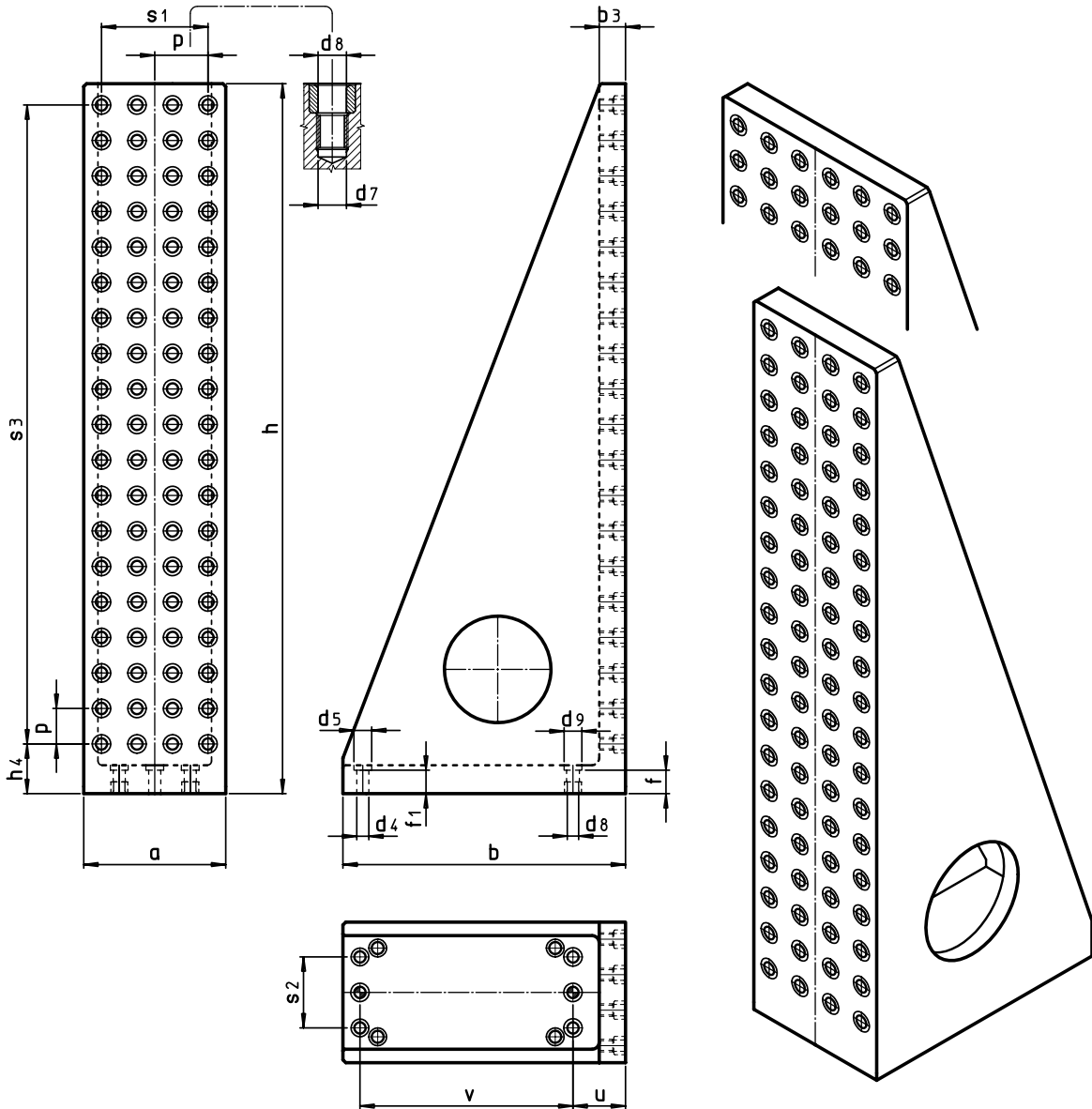

# squadre strette, con reticolo

narrow angle plates, with grid  
 equerres étroites, à grille  
 schmaler Raster-Winkels



codice-code code-Best.Nr.	a	b	h	d8	d7	p	h4	s1	s3	u	v	s2	d4	d5	nr.	vite cal-cal.scr. vis c.-p.Schrau.	vite - screw vis-Schraube	.GG kg	.AL kg
<b>044.010</b>	198	398	700	<b>16</b>	<b>M16</b>	±0.01	70	150	600	74	300	100	17	25	52	111.140	M16x60-70	85	29
<b>044.020</b>	298	448	1000	<b>16</b>	<b>M16</b>	±0.01	70	250	900	74	350	200	17	25	114	111.140	M16x60-70	165	55

indicare con la richiesta le caratteristiche di interfacciamento alla macchina - on the request put the interface features to the machine  
 il faut indiquer dans votre demande les caractéristiques d'interface à la machine - bei Anfrage bitte Info über die Maschinentisch-Schnittstelle