

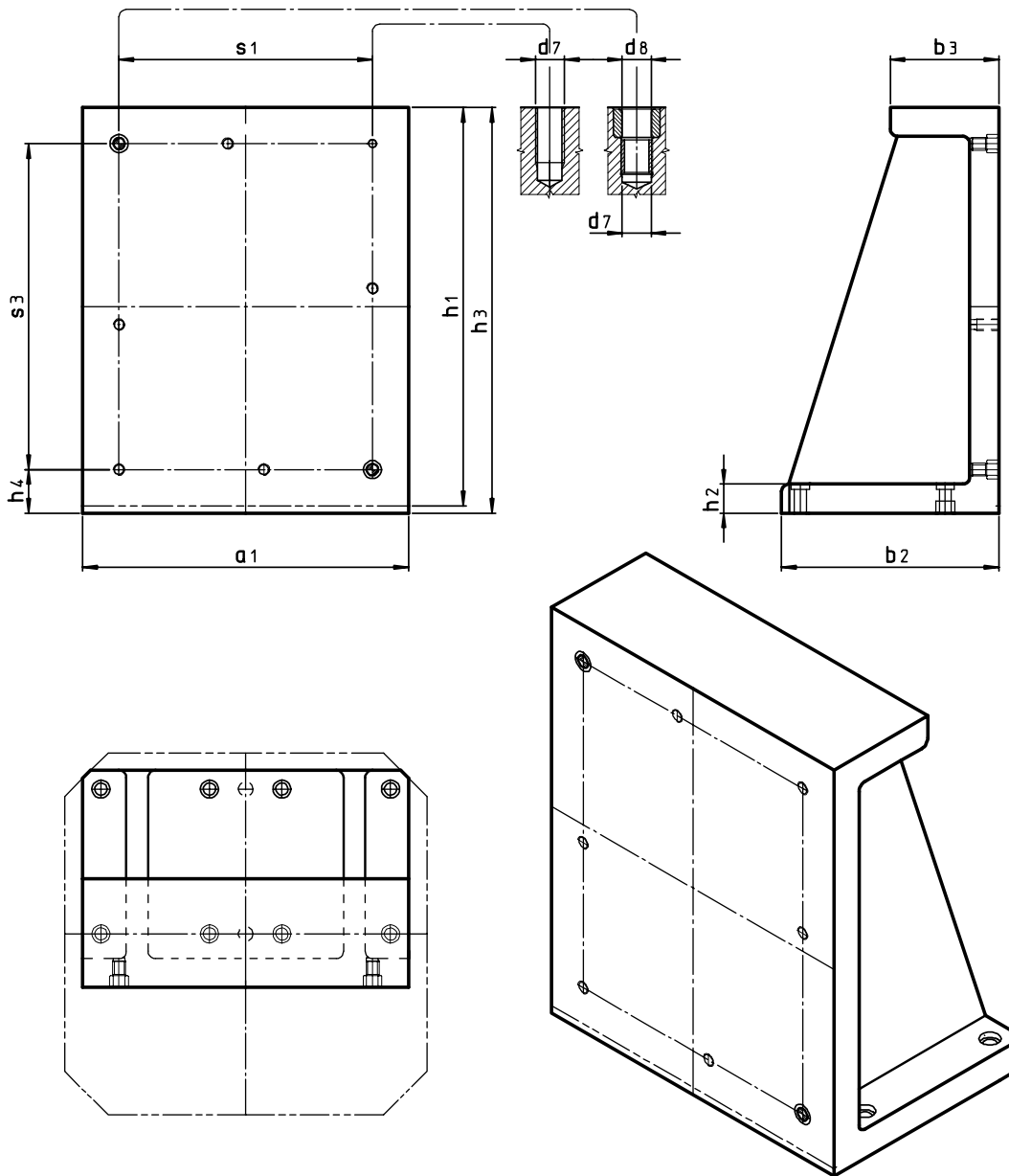

squadre a mensola, porta piastre

angle plates for plates
 équerres porte-plaques
 Aufspannwinkel für Vorrichtungplatten

04



codice-code code-Best.Nr.	a1	h1	h2	h3	b2	b3	d8	d7	h4	s1	s3	piastre - plates plaques-Platten	.GG kg	.AL kg
042.015	250	350	40	360	200	100	12	M12	60	150	250	250x350	50	18
042.025	350	350	40	360	250	100	12	M12	60	250	250	350x350	75	30
042.035	350	550	40	560	250	150	12	M12	60	250	450	350x550	110	40
042.045	450	450	40	460	300	100	12	M12	60	350	350	450x450	120	45
042.055	450	650	40	660	300	150	12	M12	60	350	550	450x650	175	65
042.065	550	550	40	560	350	150	12	M12	60	450	450	550x550	190	70
042.075	550	750	40	760	350	200	12	M12	60	450	650	550x750	260	95
042.040	750	650	40	660	400	150	16	M16	60	650	550	750x650	310	115
042.050	750	850	40	860	400	200	16	M16	60	650	750	750x850	400	150

- indicare con la richiesta le caratteristiche di interfacciamento alla macchina

- on the request put the interface features to the machine

- il faut indiquer dans votre demande les caractéristiques d'interface à la machine

- bei Anfrage bitte Info über die Palettenschnittstelle