

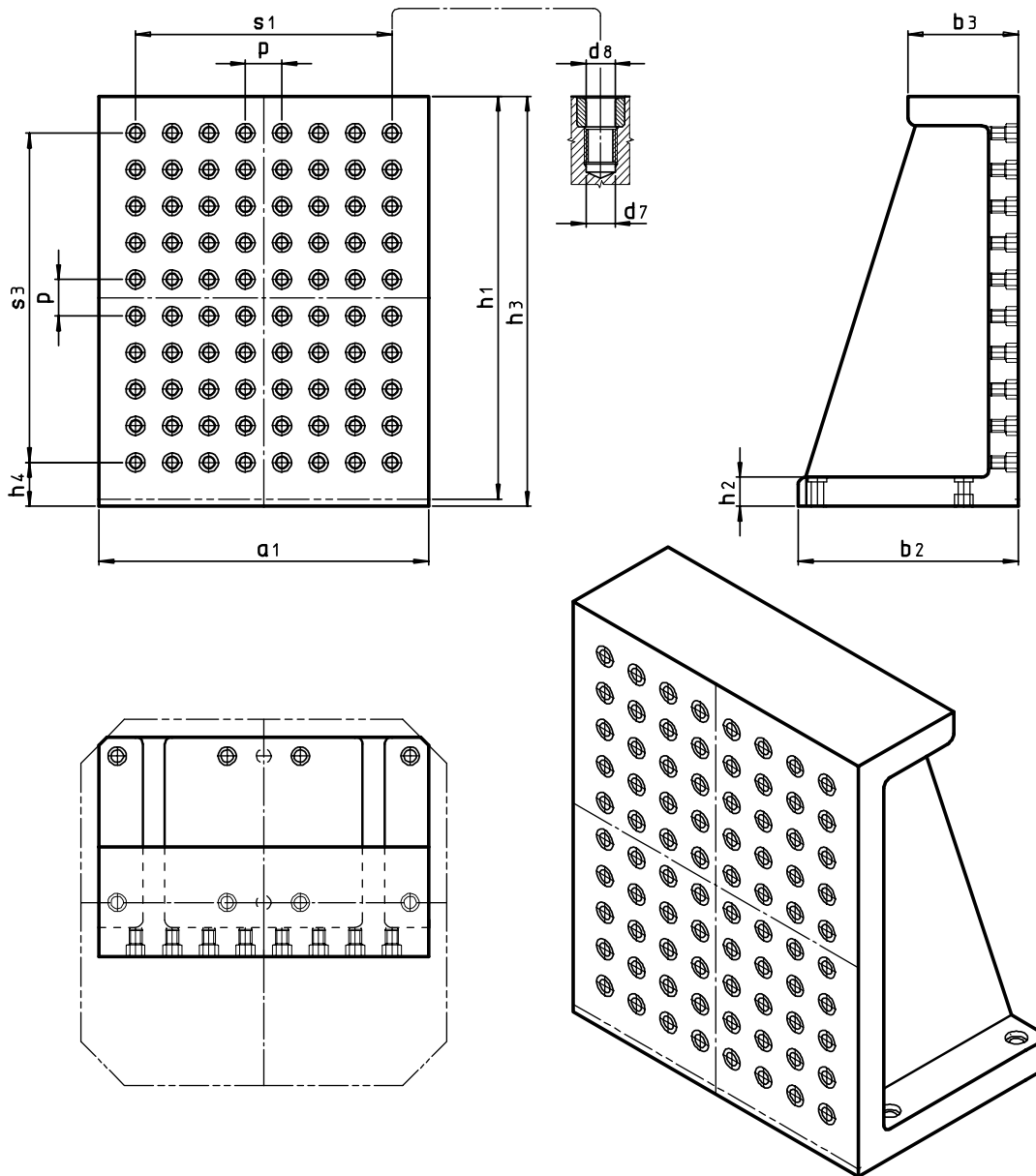

squadre a mensola, con reticolo

angle plates with grid
équerres à grille
Aufspannwinkel mit Vollraster

04



codice-code code-Best.Nr.	a1	h1	h2	h3	b2	b3	d8	d7	p	h4	s1	s3	nr. d8	piastre - plates plaques-Platten	.GG kg	.AL kg	
042.215	250	350	40	360	200	100	12	M12	50	±0.01	60	150	250	24	250x350	50	18
042.225	350	350	40	360	250	100	12	M12	50	±0.015	60	250	250	36	350x350	75	30
042.235	350	550	40	560	250	150	12	M12	50	±0.015	60	250	450	60	350x550	110	40
042.245	450	450	40	460	300	100	12	M12	50	±0.015	60	350	350	64	450x450	120	45
042.255	450	650	40	660	300	150	12	M12	50	±0.015	60	350	550	96	450x650	175	65
042.265	550	550	40	560	350	150	12	M12	50	±0.015	60	450	450	100	550x550	190	70
042.275	550	750	40	760	350	200	12	M12	50	±0.015	60	450	650	140	550x750	260	95
042.240	750	650	40	660	400	150	16	M16	50	±0.015	60	650	550	168	750x650	310	115
042.250	750	850	40	860	400	200	16	M16	50	±0.015	60	650	750	224	750x850	400	150

- indicare con la richiesta le caratteristiche di interfacciamento alla macchina
- il faut indiquer dans votre demande les caractéristiques d'interface à la machine

- on the request put the interface features to the machine
- bei Anfrage bitte Info über die Palettenschnittstelle