



# cubi quadrangolari a quattro facce, con reticolo

cubic piece-holder with grid  
cubes à grille  
Aufspannwürfel mit Voll-Raster

per pallets  
for pallets  
pour palettes  
für Paletten

DIN 55201-A1/A2  
JIS B6337

03

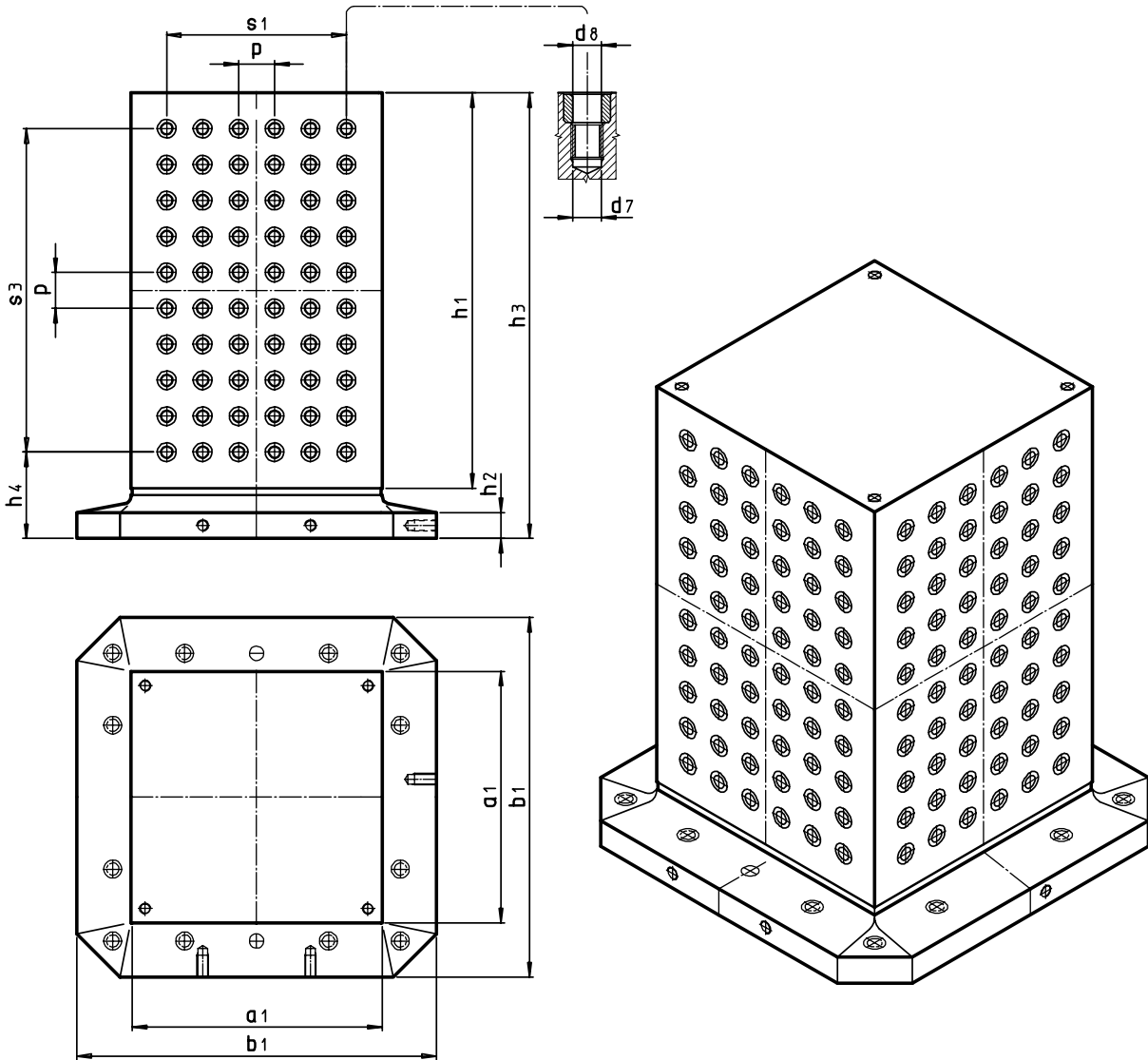

codice- code code- Best.Nr.	a1 ±0.015	h1	h2	h3	b1 stand.	d8 F7	d7	p ±0.01	h4 ±0.015	s1	s3	nr. d8	piastre - plates plaques - Platten	.GG kg	.AL kg
031.215	250	350	36	420	400	12	M12	50	120	150	250	96	250x350	145	55
031.225	250	550	36	620	400	12	M12	50	120	150	450	160	250x550	195	75
031.235	350	450	36	520	500	12	M12	50	120	250	350	192	350x450	265	100
031.245	350	650	36	720	500	12	M12	50	120	250	550	288	350x650	340	125
031.255	450	550	36	625	630	12	M12	50	125	350	450	320	450x550	430	160
031.265	450	750	36	825	630	12	M12	50	125	350	650	448	450x750	530	195
031.230	350	450	36	520	500	16	M16	50	120	250	350	192	350x450	265	100
031.240	350	650	36	720	500	16	M16	50	120	250	550	288	350x650	340	125
031.250	450	550	36	625	630	16	M16	50	125	350	450	320	450x550	430	160
031.260	450	750	36	825	630	16	M16	50	125	350	650	448	450x750	530	195
031.270	550	650	36	730	800	16	M16	50	130	450	550	480	550x650	655	245
031.280	550	850	36	930	800	16	M16	50	130	450	750	640	550x850	775	290

- indicare con la richiesta le caratteristiche di interfacciamento alla macchina  
- il faut indiquer dans votre demande les caractéristiques d'interface à la machine

- on the request put the interface features to the machine  
- bei Anfrage bitte Info über die Palettschnittstelle